



MANUAL

MANHOLEBOX Series 600



Manufacturer: **SBH Tiefbautechnik GmbH**
Ferdinand-Porsche-Str. 8
D – HEINSBERG

Telephone: +49 (0) 24 52 / 91 04 0
Telefax: +49 (0) 24 52 / 91 04 50
Email: info@sbh-shoring.com
Homepage: <http://www.sbh-shoring.com>



Table of Contents

System Sketch	3
Technical Parameters	4
Plates	4
Spindle Type 031/085 Blue	4
Accessories	5
General Information	
Lifting & Transportation	5
Measures to Reduce Hazards	6
Maintenance & Repairs	6
Assembly Instructions	7
Installation Instructions	7
Allowed Tensile Forces	7
Place and Adjust Method	7
Cut and Lower Method	8
Installation of Base Boxes	8
Installation of Top Boxes	9
Installation of Additional Shoring Units	9
Removal	10

System Sketch

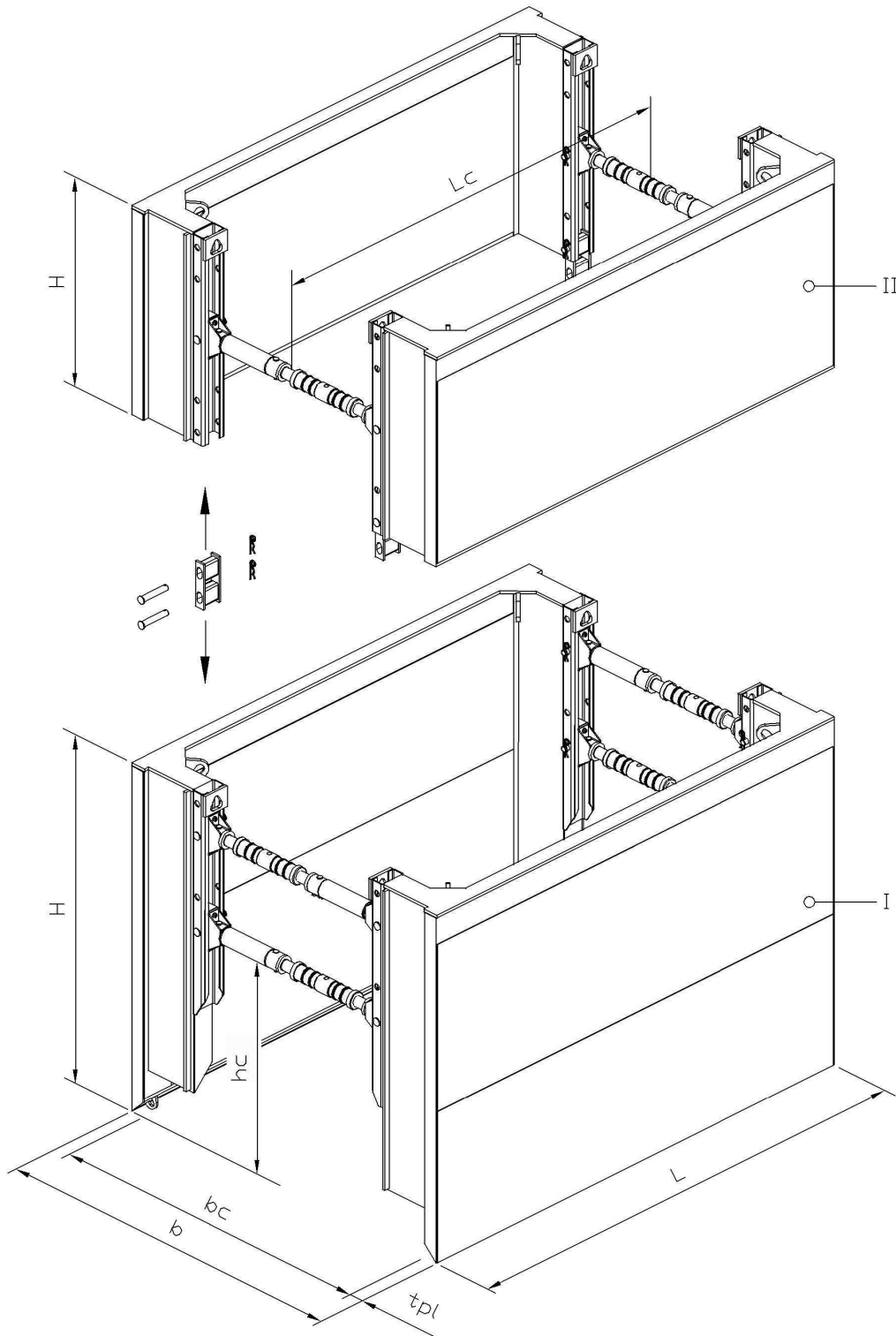

I Manhole base box
 II Manhole top box
 H Plate height

w Trench width
 w_c Working width between plates
 t_{pl} Plate thickness

h_c Pipe clearance height
 L Plate length
 H_c Pipe clearance length

MANHOLEBOX Series 600



Technical Parameters

Plate Thickness = 107 mm allowed plate moment = 79.1 kNm/m allowed side part moment = 149 kNm

Plate length L [m]	Plate height H [m]	Pipe CLR - length L _c [m]	Pipe CLR - height h _c [m]	Allowed earth pressure [kN / m ²]	Weight per box [kg]
2.50	2.50 ----- 1.50	2.10	1.69	50.1	2350 ----- 1620
3.00	2.50 ----- 1.50	2.60	1.69	41.8	2590 ----- 1780
3.50	2.50 ----- 1.50	3.10	1.69	35.8	2825 ----- 1940
4.00	2.50 ----- 1.50	3.60	1.69	31.3	3060 ----- 2095

Spindle type 031/085 blue

allowed moment = 1.7 kNm

allowed tensile forces = 218 kN

Number of extension pipes 0.50 m each	Spindle length [m]	Working width between plates w _c [m]	Trench width w [m]	Allowed compressive force F [kN]	Total weight GW [kg]
0	0.98 – 1.26	1.78 – 2.06	2.00 – 2.28	468	65.0
1	1.48 – 1.76	2.28 – 2.56	2.50 – 2.78	403	84.8
2	1.98 – 2.26	2.78 – 3.06	3.00 – 3.28	348	104.6
3	2.48 – 2.76	3.28 – 3.56	3.50 – 3.78	299	124.4
4	2.98 – 3.26	3.78 – 4.06	4.00 – 4.28	254	144.2
5	3.48 – 3.76	4.28 – 4.56	4.50 – 4.78	210	164.0
6	3.94 – 4.26	4.78 – 5.06	5.00 – 5.28	165	183.8

Accessories

No.	Designation	For use with	Dimensions [mm]	Weight [kg]
1	Spring spindle holder	Spindle	95/290 * 193	13.1
2	Spindle	Shoring plates		40.2
3	Bolt with clip 4.5	Extension pipe	Ø 20 * 147	0.4
4	Bolt with clip 6.3	Spring spindle holder and box connector	Ø 40 * 230	2.4
5	Extension pipe	Spindle	Ø 121 * 500 Ø 121 * L	19.8
6	Box connector	Top plate	70/150 * 325	7.6

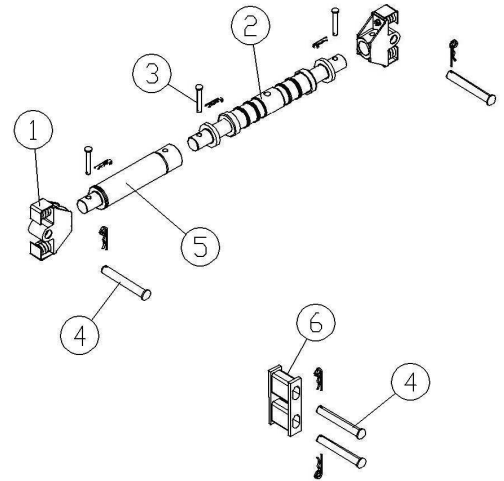

General Information

The shoring must be uninterrupted and be in contact with the ground. Ensure observance of the permissible max. stress limits. Individual shoring units may only be used if the front sides are secured appropriately.

The following sets of rules and regulations in their current versions are to be observed:

- Regulations of the BG Technical Committee for Civil Engineering
- DIN 4124 Construction Pits and Trenches
- DIN EN 13331 Part 1 & 2 Trench Shoring Equipment
- Rules for Occupational Health and Safety
- Accident prevention regulations / occupational health and safety regulations

Our shoring units bear the GS mark "Tested for Safety".

Follow the instructions in this manual during installation.

Lifting & Transportation

- The shoring unit is to be slung only by means of the dedicated lifting rings & openings or accessories.
- Mounting equipment must be suitable for the weight to be transported.
- For safety reasons, you may only use load hooks equipped with hook locks.
- Ensure the observation of the max. allowed tensile forces.
- Transportation is to be carried out close to the ground and unnecessary swinging motions are to be avoided.
- Standing in the swivel range of the lifting device or under suspended loads is prohibited.
- Look out for overhead wires.
- The machine operator and banksman must maintain eye contact.



Measures to Reduce Hazards

- The construction site must be adequately secured and signposted.
- If necessary the adjacent flow of traffic is to be ensured using additional security personnel.
- Personnel must wear protective work clothing (helmet / safety shoes / gloves).
- Possible instabilities as a result of wind load must be taken into consideration during assembly or installation.
- Store the shoring units flat, on a solid surface.
- In the case of sloping, pay special attention to stable storage of pre-assembled building components.

Maintenance and Repairs

- Shoring units should always be checked for functionality before use.
- Defective or deformed units must not be used.
- You can repair slight damage yourself after consulting with SBH. Alternatively, you can take advantage of our service at our factory, if required.
- Only use original replacement parts by SBH for repairs.
- Depending on the intensity of use, all parts should be coated with rust-proofing paint every 2 years.

Assembly Instructions

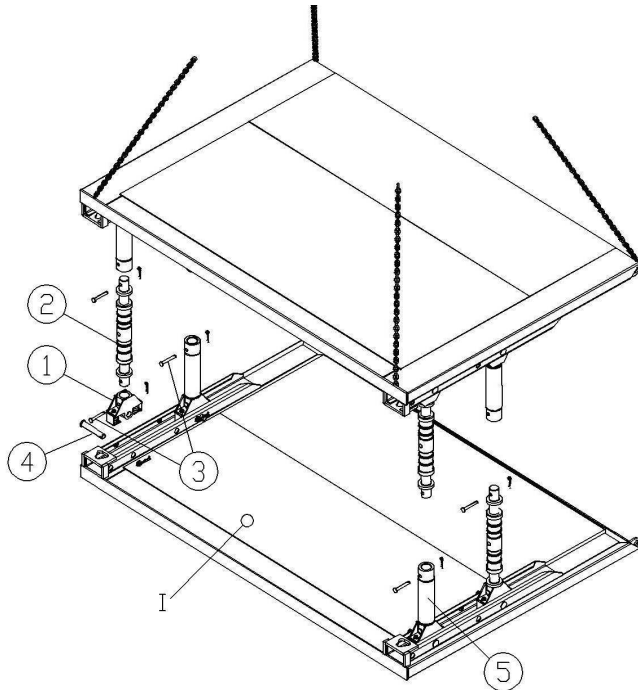

- | | | | | | |
|---|------------|---|---------------------------|---|---------------------------|
| I | Base plate | 1 | Spring spindle holder | 4 | Bolt \varnothing 40*230 |
| | | 2 | Cast spindle | 5 | Extens.pipe |
| | | 3 | Bolt \varnothing 20*147 | | |

Lay the base plate on an even and solid surface with the post pointing upwards.

Then insert the spring spindle holders into the posts, hold them in place with the \varnothing 40*230 mm bolts and secure them with clips.

Insert the spindles and extension pipes offset to each other into the spring spindle holders on one plate for trench widths of up to 2.00 m, or on both plates for greater trench widths, and secure with the \varnothing 20*147 mm bolt. Secure bolt with clips.

Perform the extension up to the required trench width via extension pipes as described in the previous section.

Once all the spindles have been put in place, mount a plate onto the designated lifting rings at the head and cutting edge or on the back of the plate and place it onto the spindles of the base plate, then bolt and secure it.

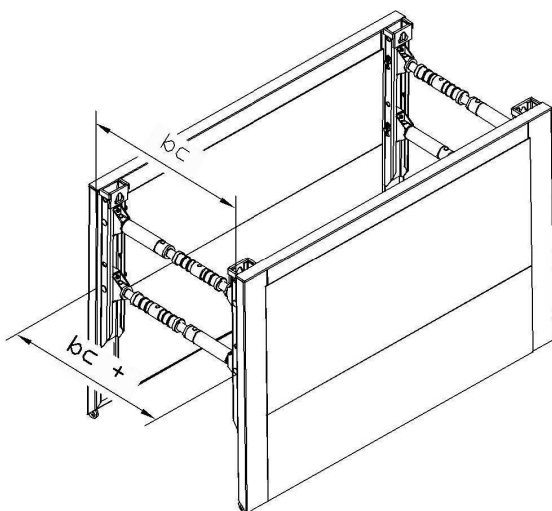

Now extend the spindles to the desired trench width (precision adjustment).

Please note that the bottom spindles need to be extended approx. 3-5 cm further to achieve an A position for the shoring plates.

The shoring width must be smaller at the top and greater at the bottom.

The assembly of the top boxes is performed analogously.

Installation Instructions

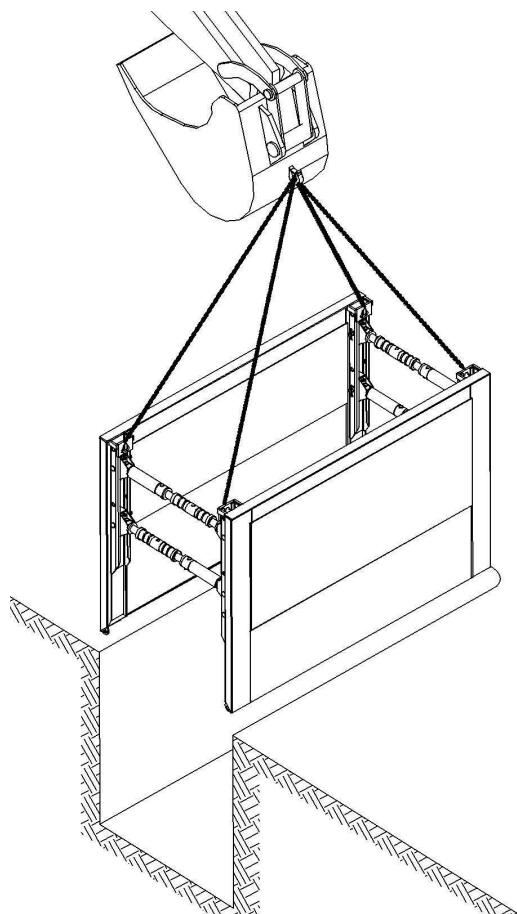

Allowed Tensile Forces

At the individual attachment points, the following tensile forces can be applied:

per lifting ring by the post	= 153 kN
per lifting ring in the top corners	= 142 kN
per lifting ring in the cutting edge	= 49 kN

Place and Adjust Method

Place the shoring box into the trench, previously excavated up to the final depth.

The place and adjust method is only valid if the following conditions are met:

- temporarily stable ground
- outside the area of influence of buildings or physical structures
- outside the influence of traffic areas and vulnerable transmission infrastructure
- Subsidence is acceptable

A ground is termed temporarily stable if it does not pose any significant disadvantages during the time between excavation and shoring system installation.

For trench depths greater than the height of the base plates, the assembly of base and top boxes must be performed outside the trench during the place and adjust method, and the system must be placed in the trench as a whole.

Connect the base and top box using box connectors and bolts, and secure them with clips.

Attach the chains to at least four of the designated lifting rings on the posts.

Place the completely assembled unit with base and top boxes into the completely excavated trench using a lifting device and suitable lifting tackle.

The excavation length must be limited to one box length. The gaps between the shoring and the ground must be filled and sealed.

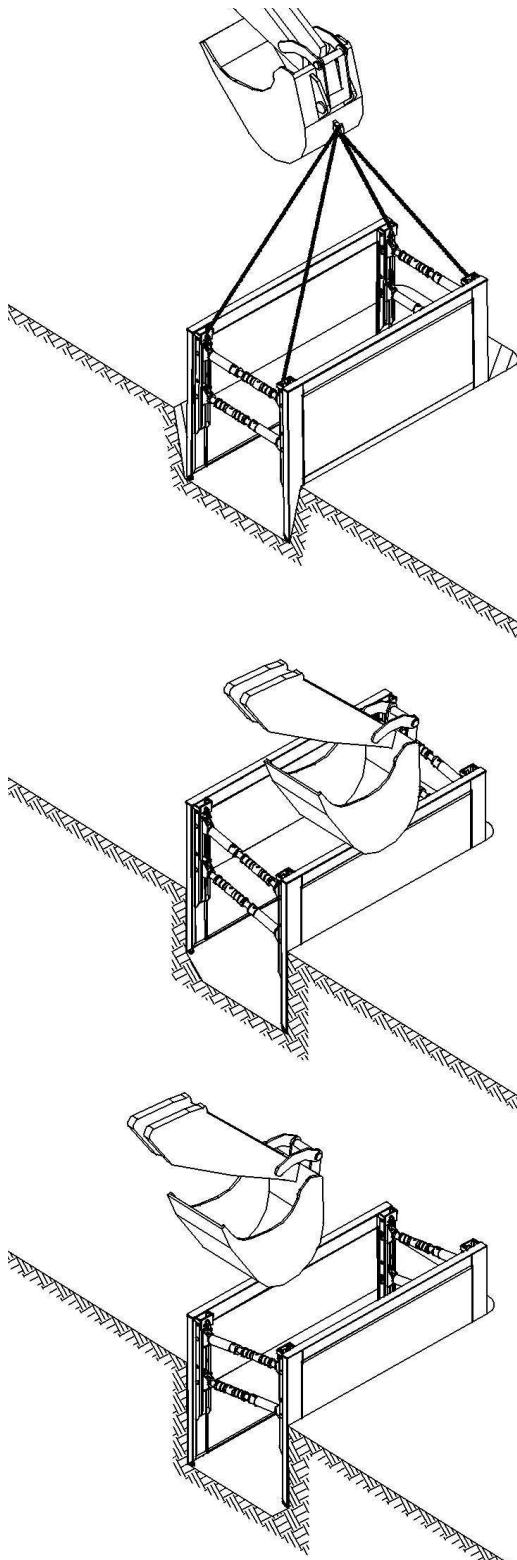

Cut and Lower Method

In case of non-stable ground, install the shoring box using shifting pressure, i.e. lowering.

Installation of Base Boxes

Advance excavation max. 1.25 m and not more than one shoring unit length. Generally, the advance excavation is performed according to ground / soil type and safety regulations.

With the chains attached to the four lifting rings on the posts, place the base box (extended to the trench width) into the advance excavation, adjust it, and push it down.

The gaps between the shoring and the ground must be filled and sealed!

The shoring plates must be pushed down, not hammered in. For safety reasons, pressing the extension pipes is prohibited.

During this phase no one may enter the trench.

Excavate approx. another 0.50 m and push the plates down further by alternating pressure between the plates.

The less pressure put on each push, the better for the shoring! Do not push down further than 0.50 m on one side, and limit the rotation angle of the spindles to $\pm 8^\circ$. Repeat the procedure, until the required trench depth has been reached.

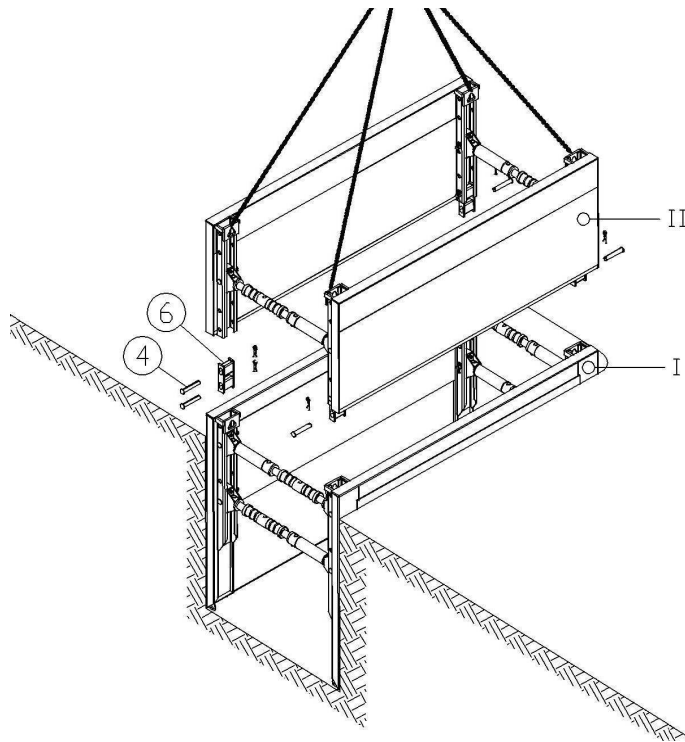

I Base box
II Top box

4 Bolt \varnothing 40*230
6 Box connector

Installation of Top Boxes

Use top boxes for greater installation depths. Align the top box (pre-assembled at trench width and suspended by the four lifting rings on the posts) with the base box and attach using box connectors and \varnothing 40*230 mm bolts.

Perform further installation as described above by alternating excavation and impression of the shoring plates.

The top edge of the shoring must stand at least 5 cm above the surrounding terrain!

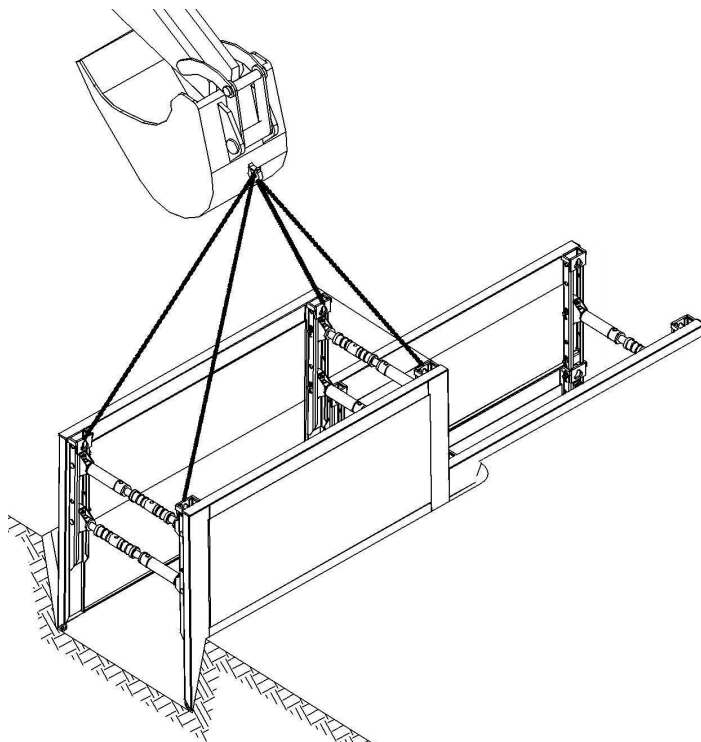

Installation of Additional Shoring Units

Once the previous shoring unit is installed at the full depth, you can begin with the next shoring unit.

Perform the installation according to the previously described procedure.

After the installation of the shoring units, you can begin laying the pipes in the secured utility trench.

Removal

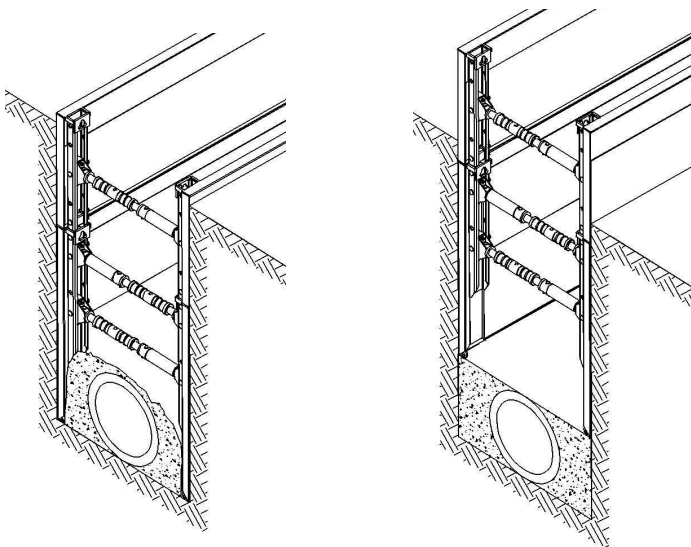

Once the pipe installation is completed, the shoring must be removed.

Depending on compacting options, add max. 0.50 m filling material. Lift the shoring box by the filled up height. Then compact the filling material.

The less pressure put on each pull, the better for the shoring! Do not pull more than 0.50 m on one side, and limit the rotation angle of the spindles to $\pm 8^\circ$.

Repeat the procedure as described until the shoring can be removed according to safety regulations.

Only use the designated lifting rings to pull the shoring boxes. Pulling the extension pipes is not permitted!

We expressly point out that both during installation and removal, standing within the danger zone is prohibited.

To avoid excessive strain on the shoring plates, one-sided pulling operations must be avoided. Lifting tackle must be attached to at least 2 lifting rings per plate.